

HEYU/GEO | 800 DRAWER LINE STORAGE UNIT - PUSH TO OPEN

HYS039/*, HYL039/***, HYW039/***, HYR039/*****

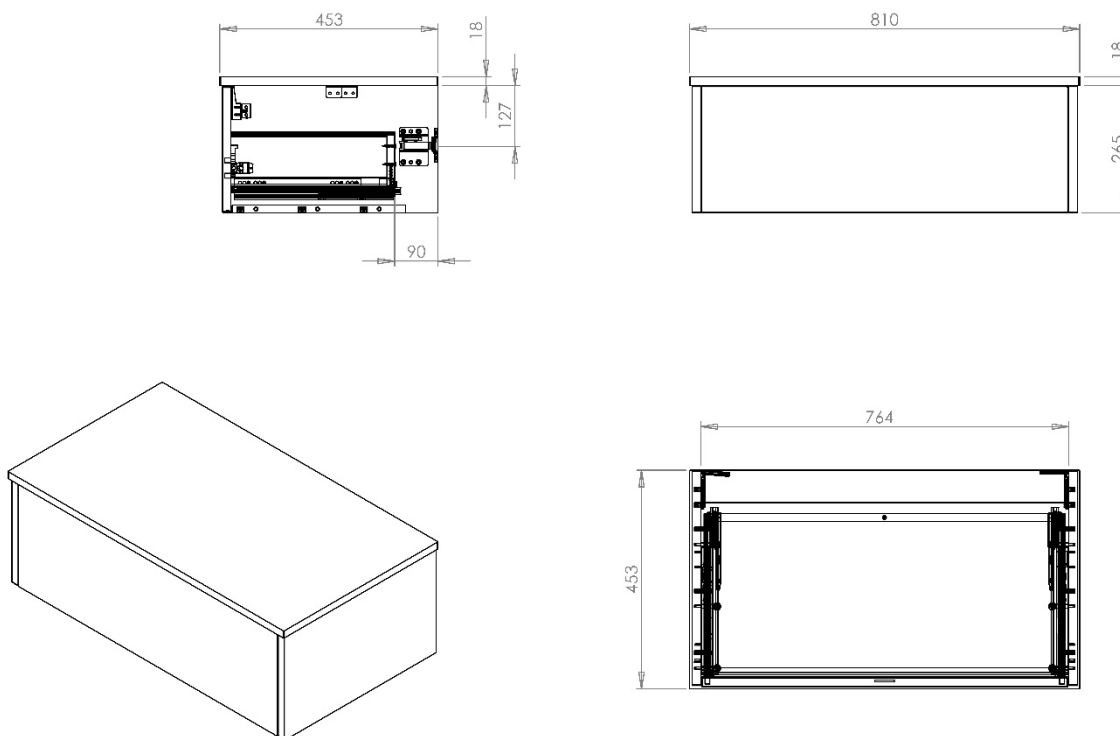

All dimension in mm. Please check dimensions prior to installation as they can vary due to manufacturing tolerances.

Product Details

Type:	Single Drawer Line Storage
Width:	800
Depth:	450
Height:	265
Product Weight*:	17.803kg
Tolerances:	+/- 2mm
Guarantee Period:	5 Years (For Domestic Use) 1 Years (For Commercial Use)
Drawer Box Capacity:	30kg

Product Specification

Fascia Material:	18mm MDF
Carcass Material:	18mm MDF/16mm MFC
Available accessories:	Please refer to the Pricelist for further details
Opening Mechanism:	Push to Open
Adjustable Legs:	N/A
Quantity of Shelves:	N/A
Shelving Type:	N/A
Handing:	N/A

*Product Weight includes packaging.

Features

- FSC Certified
- Soft Close
- Assembled
- Handleless
- Push to Open

Additional Documentation

Additional Documentation available on our website www.utopiagroup.com

Every effort has been made to ensure that the information provided on this document is correct at the time of creation. Finally, Utopia Furniture Ltd reserve the right to alter materials and specifications in line with continuing programme of production and service development.

HEYU/GEO | 800 STORAGE UNIT - PULL

HYS038/*, HYL038/***, HYW038/***, HYR038/*****

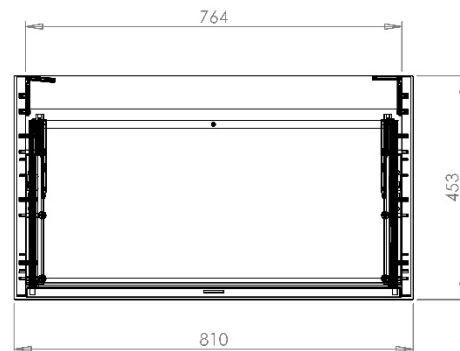
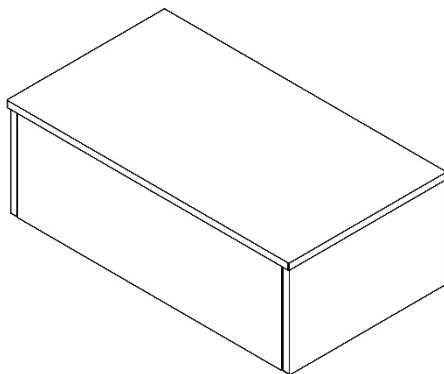
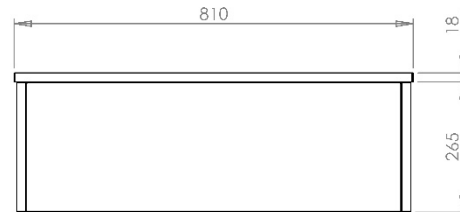
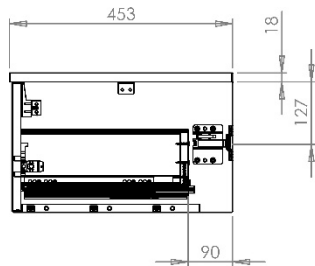

All dimension in mm. Please check dimensions prior to installation as they can vary due to manufacturing tolerances.

Product Details

Type:	Single Drawer Line Storage
Width:	800
Depth:	448
Height:	265
Product Weight*:	17.803kg
Tolerances:	+/- 2mm
Guarantee Period:	5 Years (For Domestic Use) 1 Years (For Commercial Use)
Drawer Box Capacity:	30kg

Product Specification

Fascia Material:	18mm MDF
Carcass Material:	18mm MDF/16mm MFC
Available accessories:	Please refer to the Pricelist for further details
Opening Mechanism:	Pull Handle
Adjustable Legs:	N/A
Quantity of Shelves:	N/A
Shelving Type:	N/A
Handing:	N/A

*Product Weight includes packaging.

Features

- FSC Certified
- Soft Close
- Assembled

Additional Documentation

Additional Documentation available on our website www.utopiagroup.com

Every effort has been made to ensure that the information provided on this document is correct at the time of creation. Finally, Utopia Furniture Ltd reserve the right to alter materials and specifications in line with continuing programme of production and service development.

HEYU/GEO | 1200 STORAGE UNIT - PUSH TO OPEN

HYS041/*, HYL041/***, HYW041/***, HYR041/*****

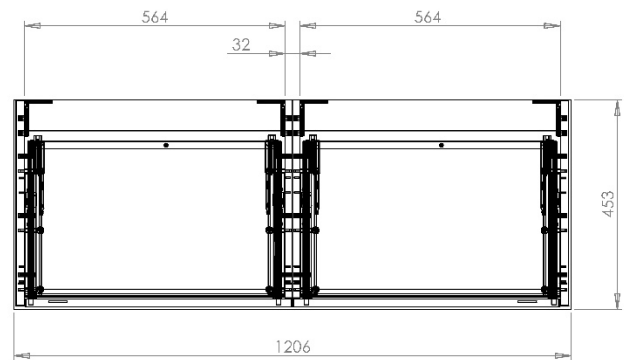
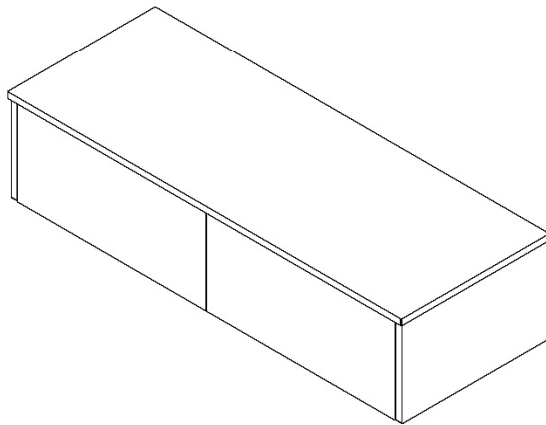
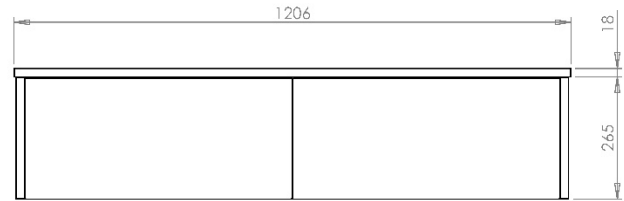
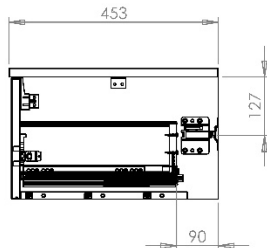

All dimension in mm. Please check dimensions prior to installation as they can vary due to manufacturing tolerances.

Product Details

Type:	Twin Single Drawer Line Storage
Width:	1196
Depth:	450
Height:	265
Product Weight*:	29.914kg
Tolerances:	+/- 2mm
Guarantee Period:	5 Years (For Domestic Use) 1 Years (For Commercial Use)
Drawer Box Capacity:	30kg

Product Specification

Fascia Material:	18mm MDF
Carcass Material:	18mm MDF/16mm MFC
Available accessories:	Please refer to the Pricelist for further details
Opening Mechanism:	Push to Open
Adjustable Legs:	N/A
Quantity of Shelves:	N/A
Shelving Type:	N/A
Handing:	N/A

*Product Weight includes packaging.

Features

- FSC Certified
- Soft Close
- Assembled
- Handleless
- Push to Open

Additional Documentation

Additional Documentation available on our website www.utopiagroup.com

Every effort has been made to ensure that the information provided on this document is correct at the time of creation. Finally, Utopia Furniture Ltd reserve the right to alter materials and specifications in line with continuing programme of production and service development.

HEYU/GEO | 1200 STORAGE UNIT - PULL

HYS040/*, HYL040/***, HYW040/***, HYR040/*****

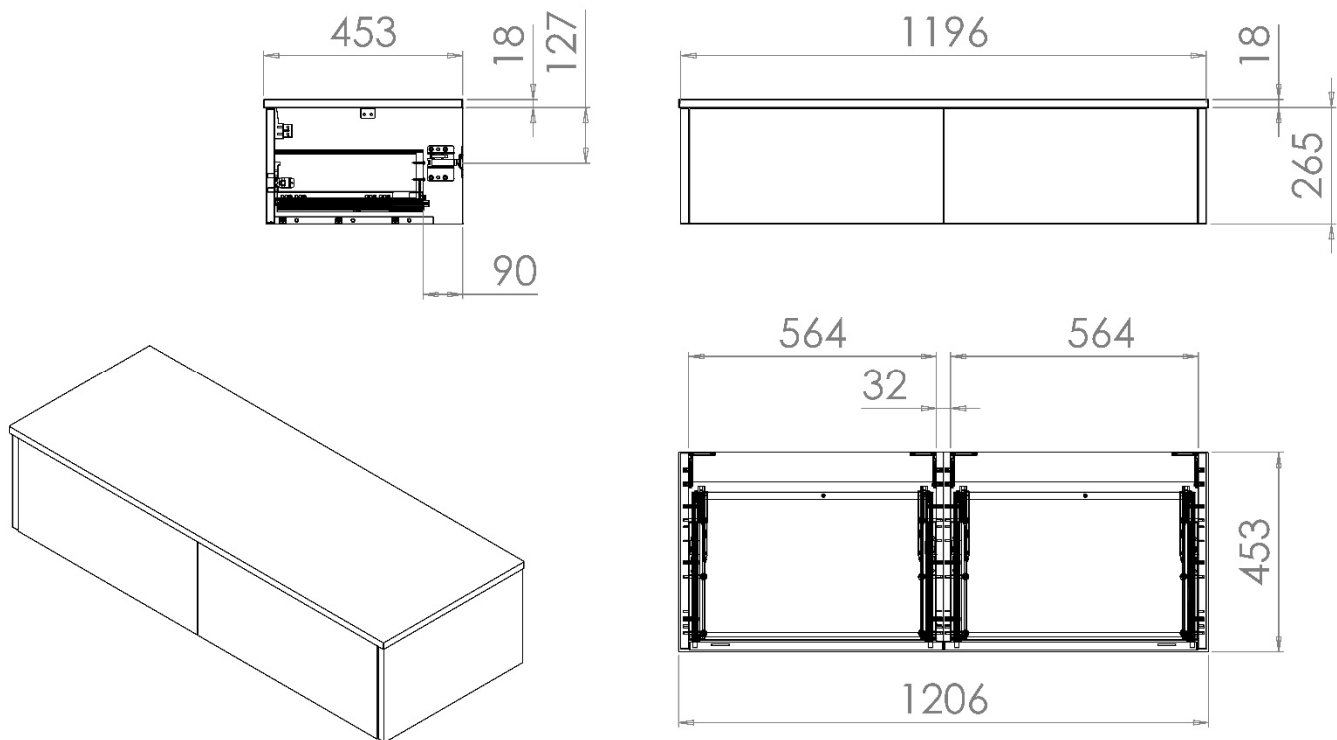

All dimension in mm. Please check dimensions prior to installation as they can vary due to manufacturing tolerances.

Product Details

Type:	Twin Single Drawer Line Storage
Width:	1196
Depth:	448
Height:	265
Product Weight*:	29.914kg
Tolerances:	+/- 2mm
Guarantee Period:	5 Years (For Domestic Use) 1 Years (For Commercial Use)
Drawer Box Capacity:	30kg

Product Specification

Fascia Material:	18mm MDF
Carcass Material:	18mm MDF/16mm MFC
Available accessories:	Please refer to the Pricelist for further details
Opening Mechanism:	Pull Handle
Adjustable Legs:	N/A
Quantity of Shelves:	N/A
Shelving Type:	N/A
Handing:	N/A

*Product Weight includes packaging.

Features

- FSC Certified
- Soft Close
- Assembled

Additional Documentation

Additional Documentation available on our website www.utopiagroup.com

Every effort has been made to ensure that the information provided on this document is correct at the time of creation. Finally, Utopia Furniture Ltd reserve the right to alter materials and specifications in line with continuing programme of production and service development.

HEYU/GEO | 1600 STORAGE UNIT - PUSH TO OPEN

HYS043/*, HYL043/***, HYW043/***, HYR043/*****

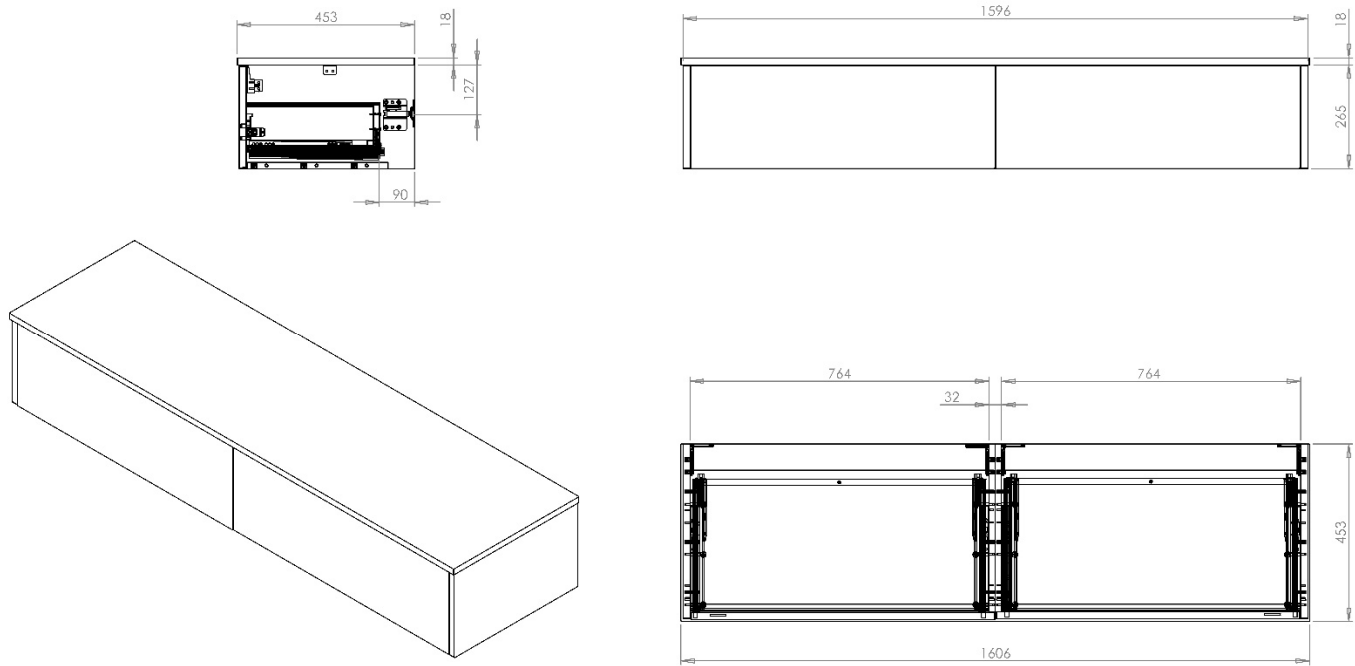

All dimension in mm. Please check dimensions prior to installation as they can vary due to manufacturing tolerances.

Product Details

Type:	Twin Single Drawer Line Storage
Width:	1596
Depth:	450
Height:	265
Product Weight*:	17.803kg
Tolerances:	+/- 2mm
Guarantee Period:	5 Years (For Domestic Use) 1 Years (For Commercial Use)
Drawer Box Capacity:	30kg

Product Specification

Fascia Material:	18mm MDF
Carcass Material:	18mm MDF/16mm MFC
Available accessories:	Please refer to the Pricelist for further details
Opening Mechanism:	Push to Open
Adjustable Legs:	N/A
Quantity of Shelves:	N/A
Shelving Type:	N/A
Handing:	N/A

*Product Weight includes packaging.

Features

- FSC Certified
- Soft Close
- Assembled
- Handleless
- Push to Open

Additional Documentation

Additional Documentation available on our website www.utopiagroup.com

Every effort has been made to ensure that the information provided on this document is correct at the time of creation. Finally, Utopia Furniture Ltd reserve the right to alter materials and specifications in line with continuing programme of production and service development.

HEYU/GEO | 1600 DRAWER LINE STORAGE UNIT - PULL

HYS042/*, HYL042/***, HYW042/***, HYR042/*****

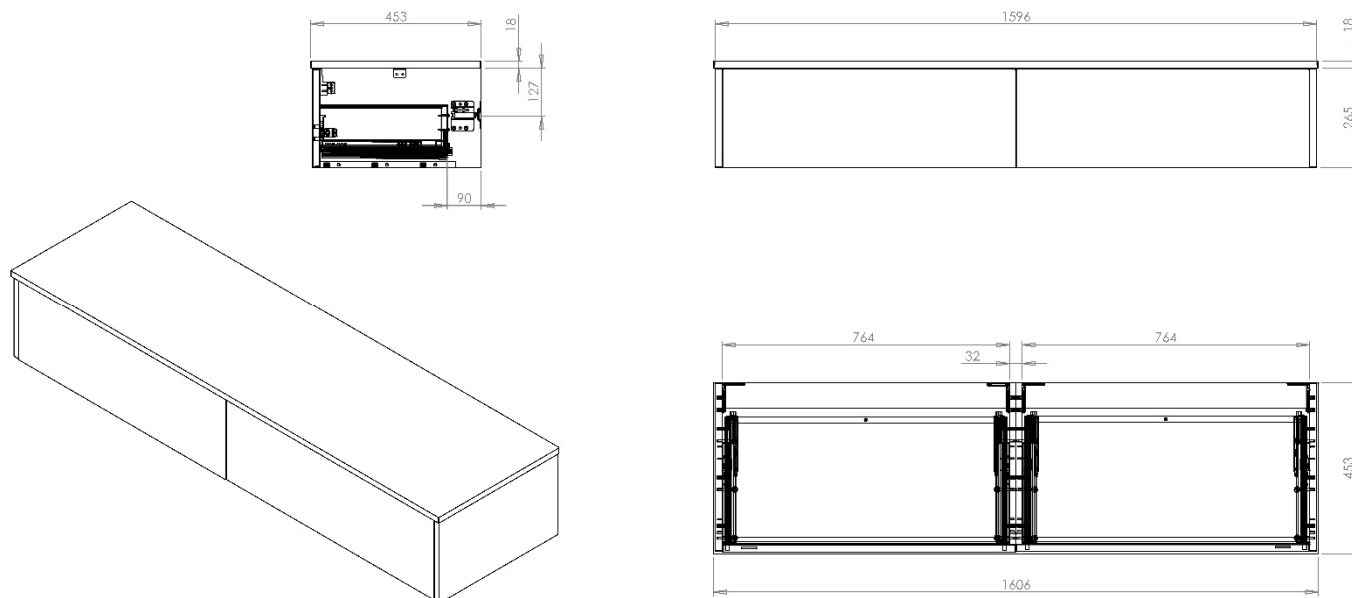

All dimension in mm. Please check dimensions prior to installation as they can vary due to manufacturing tolerances.

Product Details

Type:	Twin Single Drawer Line Storage
Width:	1596
Depth:	448
Height:	265
Product Weight*:	17.803kg
Tolerances:	+/- 2mm
Guarantee Period:	5 Years (For Domestic Use) 1 Years (For Commercial Use)
Drawer Box Capacity:	30kg

Product Specification

Fascia Material:	18mm MDF
Carcass Material:	18mm MDF/16mm MFC
Available accessories:	Please refer to the Pricelist for further details
Opening Mechanism:	Pull Handle
Adjustable Legs:	N/A
Quantity of Shelves:	N/A
Shelving Type:	N/A
Handing:	N/A

*Product Weight includes packaging.

Features

- FSC Certified
- Soft Close
- Assembled

Additional Documentation

Additional Documentation available on our website www.utopiagroup.com

Every effort has been made to ensure that the information provided on this document is correct at the time of creation. Finally, Utopia Furniture Ltd reserve the right to alter materials and specifications in line with continuing programme of production and service development.