

Important Information

- Read the instructions carefully.
- Check the product for any signs of damage and remove any protective film.
- It is recommended that a technically competent installer undertakes installation.
- It is the installer's responsibility to carry out a thorough assessment of the wall type and the weight of the cabinet and use appropriate fixings.
- Care should be taken when drilling walls to avoid any hidden wires or pipes.
- The optional legs are decorative and not designed to be load bearing.

Installation

Remove the drawer from the cabinet. Mark a horizontal line on the wall at the required height **X---X**. Ensure that the wall brackets will fit inside the width of the cabinet and are equally spaced to ensure even distribution of weight. Secure the wall brackets to the wall using correct fixing for the wall type.

Hook the unit onto the wall brackets ensuring that the spring locks the arm into place.

To alter the position of the cabinet on the wall, adjust the two screws in each hanging bracket. Adjusting screws **A** will move the cabinet up and down. When the cabinet is level on the wall, screws **B** will tighten the cabinet to the wall.

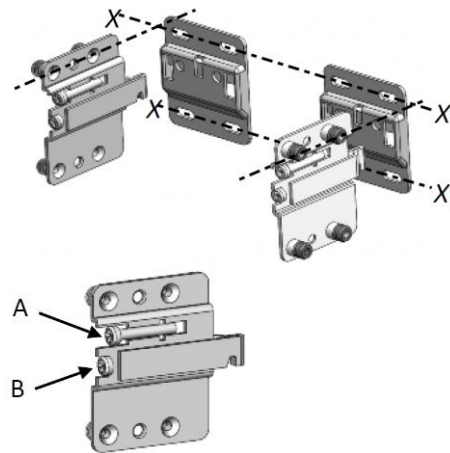

If you have ordered a pull-to-open washbasin unit, mark and drill the drawer front to suit your chosen door handle. We recommend that door handle is fitted central to the drawer front and 50mm from the edge. Refit the drawer back into the cabinet. It is good practise to run a bead of silicone where the furniture meets the wall.

Drawer Box Removal and Replacement

To remove the drawer box, pull the drawer fully out and lift it upwards. To re-fit the drawer box, pull the runners fully out, place the drawer box on the runners and push it rearwards until it clicks into place.

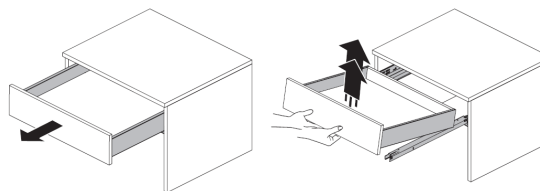

Drawer Front Removal

Slide the drawer side covers rearwards to expose the screws. Using a crosshead screwdriver, turn the screws shown to release the drawer front.



Where there are two screws on each drawer side, turn the top screw first followed by the bottom one.



Drawer Front Adjustment - Up and Down

Slide the drawer side covers rearwards to expose the adjustment screws. To raise or lower the drawer front, turn the larger screws with a crosshead screwdriver until adjusted as required. Turning the screws clockwise will move the drawer front upwards.

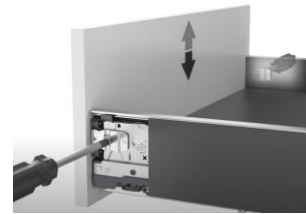

Drawer Front Adjustment – Left to Right

Slide the drawer side covers rearwards to expose the adjustment screws. To move the drawer front from side to side, turn the smaller screws with a crosshead screwdriver until adjusted as required. Turning the screw in the right-hand side clockwise and the screw in the left-hand side anti-clockwise will move the drawer front to the right.

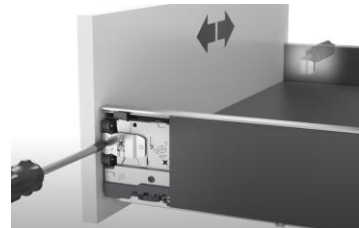

Drawer Front Adjustment - Tilt

Slide the drawer side covers rearwards to expose the adjustment screws. Remove the caps from the tops of the drawer sides. Turning the screws clockwise with a cross-head screwdriver will tilt the drawer front backwards.

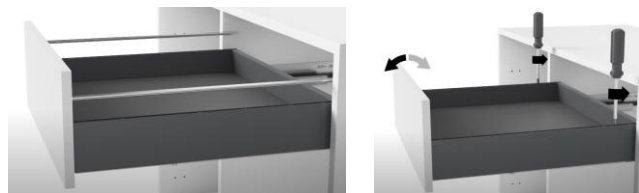

Care & Maintenance

Furniture should be regularly dusted with a soft cotton or micro-fibre cloth. For more thorough cleaning, occasionally wipe your furniture with a soft cloth dampened with a mild detergent solution. Surfaces should be thoroughly dried with a lint free cloth to prevent watermarks. Under no circumstances should solvent cleaning agents, bleach or abrasive cleaning agents or cloths be used. Spills should be removed immediately using a clean cloth. All bathroom furniture will deteriorate through prolonged periods of exposure to high levels of condensation so bathrooms must be adequately ventilated using suitable extraction. Failure to ensure adequate ventilation may invalidate your guarantee.

Optional Drawer Lighting Pack

Installation

Remove the drawer box from the cabinet. Pull the drawer out to its full extension and lift it upwards away from the drawer runners.

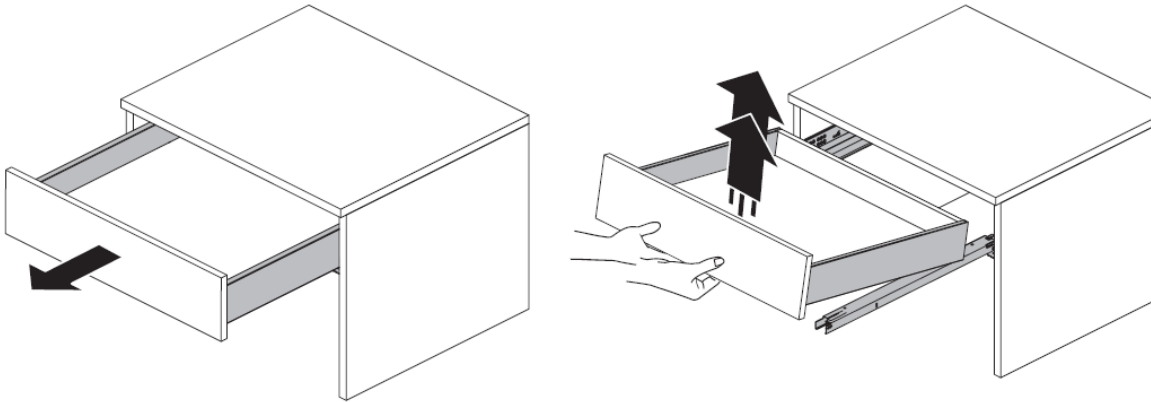

Remove the cover cap strips from the top of the drawer box sides by carefully pulling them upwards.

Clip the lighting strips onto the drawer box sides ensuring that the cables are at the rear of the drawer box.

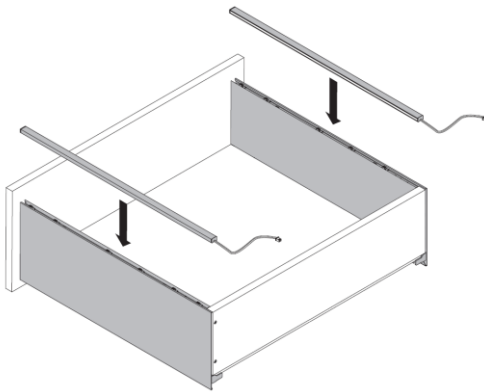

Screw the battery pack in its holder onto the rear of the drawer box. The battery pack must be fitted flush to the top of the drawer box and as far over to the right of the drawer box as possible. A spacer is included if it is required to move the battery box further away from the drawer back.

Plug the cables from the light strips firmly into the battery pack. It may be necessary to use the supplied extension cable between the light strips and the battery pack. Stick the cable clips onto the rear of the drawer box to hold the cables in position. For drawers with a waste cutout, route the cables around the cutout.

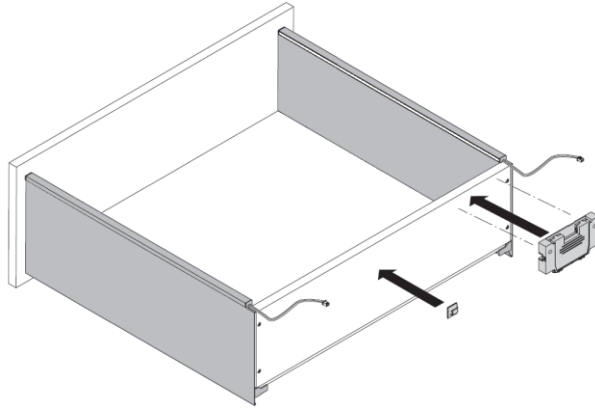

Screw the magnetic sensor to the gable inside the unit. It may be necessary to remove the plastic grommet and screw from the sensor and use the supplied woodscrew instead. To determine the best position, refit the drawer box and view the cabinet from the rear. Fit the sensor so that it is level with the moulded sensor marks on the battery pack holder. The sensor must be positioned so that it lines up with the battery pack when the drawer is closed.

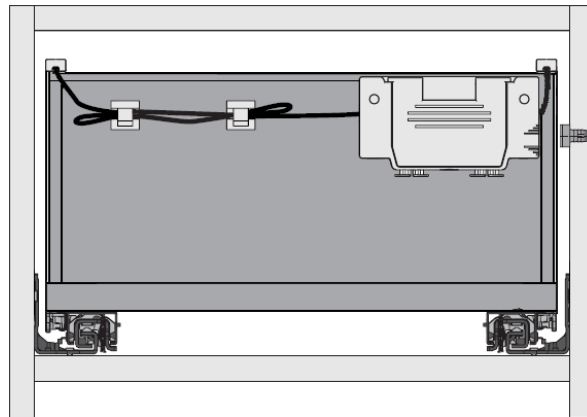
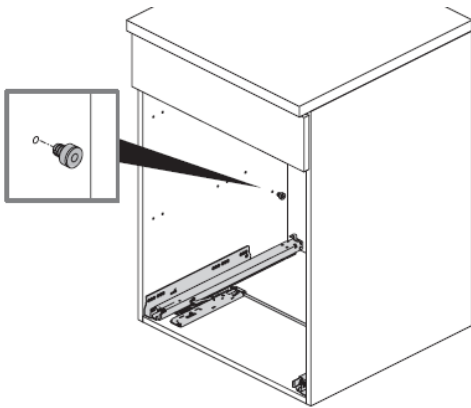

To recharge the battery pack, pull the drawer out and lift the battery pack from the holder. The battery pack should be recharged with a micro USB cable (supplied). Charging time is approximately 4 hours with a 500mA charger. Replace the battery pack in the holder when it is fully charged.

Important Information

- Read the instructions carefully.
- Ensure product contents are complete.
- Check the product for any signs of damage and remove all protective film.
- It is recommended that a technically competent installer undertakes installation.
- It is the installer's responsibility to carry out a thorough assessment of wall type and the weight of the cabinet and use appropriate fixings.
- Care should be taken when drilling to avoid any hidden wires or pipes.
- The optional legs are decorative and not designed to be load bearing.

Installation

Remove the door from the cabinet (the diagram lower down shows how to release the hinges).

It may be necessary to snap the wall plate in half at the marked line to create two wall brackets.



Mark a horizontal line on the wall at the required height X---X. Ensure that the wall brackets will fit inside the width of the cabinet and are equally spaced to ensure even distribution of weight. Secure the wall brackets to the wall using suitable fixings.

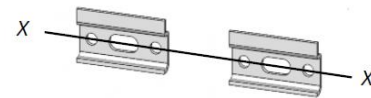

Hook the unit onto the wall brackets ensuring that the brackets are securely located.

To adjust the position of the cabinet on the wall, use the two screws in each hanging bracket. Adjusting screws B will move the cabinet up and down. When the cabinet is level on the wall, screws A will tighten the cabinet to the wall.

A further fixing should be fitted through the back of the unit into the wall. This will help to stabilise the unit.

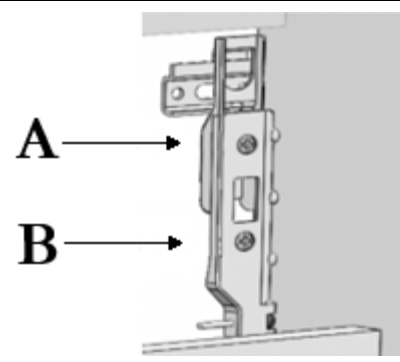

If you have ordered a pull-to-open cloakroom unit, mark and drill the drawer front to suit your chosen door handle. We recommend that door handle is fitted central to the drawer front and 50mm from the edge. Refit the drawer back into the cabinet.

Secure the basin to the cabinet using a good quality, sanitary-grade silicone sealant. It is good practise to run a bead of silicone where the furniture and basin meets the wall.

Door hinge adjustment

To square the door against the cabinet, turn screws A until adjusted as required.

To adjust the door closer to or further away from the cabinet, turn screws B.

To adjust the door vertically, slacken screws C. Re-tighten once the door is adjusted as required.

To remove the door hinges from the cabinet, press button D.

To remove the door hinges from the door, remove screws E.

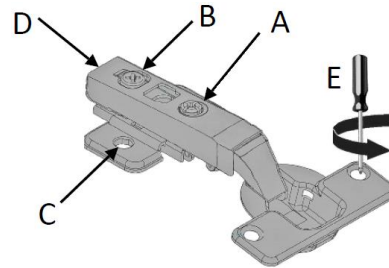

Care & Maintenance

Furniture should be regularly dusted with a soft cotton or micro-fibre cloth. For more thorough cleaning, occasionally wipe your furniture with a soft cloth dampened with a mild detergent solution. Surfaces should be thoroughly dried with a lint free cloth to prevent watermarks. Under no circumstances should solvent cleaning agents, bleach or abrasive cleaning agents or cloths be used. Spills should be removed immediately using a clean cloth. All bathroom furniture will deteriorate through prolonged periods of exposure to high levels of condensation so bathrooms must be adequately ventilated using suitable extraction. Failure to ensure adequate ventilation may invalidate your guarantee.

Installation Guide

Chic Tall Storage Unit

Important Information

- Read the instructions carefully.
- Check the product for any signs of damage and remove any protective film.
- It is recommended that a technically competent installer undertakes installation.
- It is the installer's responsibility to carry out a thorough assessment of the wall type and the weight of the cabinet and use appropriate fixings.
- Care should be taken when drilling walls to avoid any hidden wires or pipes.
- The optional legs are decorative and not designed to be load bearing.

Installation

Remove the door from the cabinet (the diagram lower down shows how to release the hinges).

It may be necessary to snap the wall plate in half at the marked line to create two wall brackets.



Mark a horizontal line on the wall at the required height X--X. Ensure that the wall brackets will fit inside the width of the cabinet and are equally spaced to ensure even distribution of weight. Secure the wall brackets to the wall using suitable fixings.

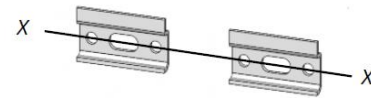

Hook the unit onto the wall brackets ensuring that the brackets are securely located.

To adjust the position of the cabinet on the wall, use the two screws in each hanging bracket. Adjusting screws B will move the cabinet up and down. When the cabinet is level on the wall, screws A will tighten the cabinet to the wall.

A further fixing should be fitted through the back of the unit into the wall. This will help to stabilise the unit.

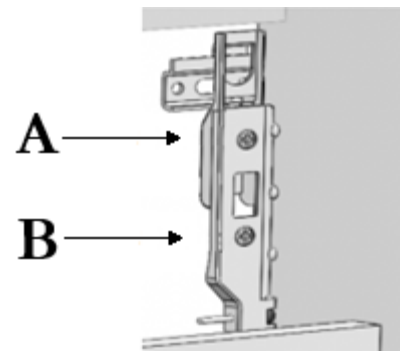

If you have ordered a pull-to-open cloakroom unit, mark and drill the drawer front to suit your chosen door handle. We recommend that door handle is fitted central to the drawer front and 50mm from the edge. Refit the drawer back into the cabinet.

Secure the basin to the cabinet using a good quality, sanitary-grade silicone sealant. It is good practise to run a bead of silicone where the furniture and basin meets the wall.

Door hinge adjustment

To square the door against the cabinet, turn screws A until adjusted as required.

To adjust the door closer to or further away from the cabinet, turn screws B.

To adjust the door vertically, slacken screws C. Re-tighten once the door is adjusted as required.

To remove the door hinges from the cabinet, press button D.

To remove the door hinges from the door, remove screws E.

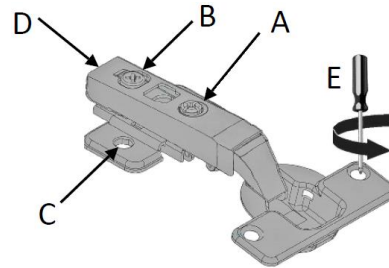

Care & Maintenance

Furniture should be regularly dusted with a soft cotton or micro-fibre cloth. For more thorough cleaning, occasionally wipe your furniture with a soft cloth dampened with a mild detergent solution. Surfaces should be thoroughly dried with a lint free cloth to prevent watermarks. Under no circumstances should solvent cleaning agents, bleach or abrasive cleaning agents or cloths be used. Spills should be removed immediately using a clean cloth. All bathroom furniture will deteriorate through prolonged periods of exposure to high levels of condensation so bathrooms must be adequately ventilated using suitable extraction. Failure to ensure adequate ventilation may invalidate your guarantee.

Important Information

- Read the instructions carefully.
- Check the product for any signs of damage and remove any protective film.
- It is recommended that a technically competent installer undertakes installation.
- It is the installer's responsibility to carry out a thorough assessment of the wall type and the weight of the cabinet and use appropriate fixings.
- Care should be taken when drilling walls to avoid any hidden wires or pipes.

Installation

Remove the top fascia panel first by pulling it away from the cabinet with equal force on both sides.

Remove the lower fascia by lifting it upwards.

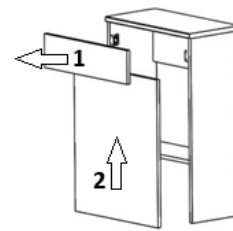

Secure the unit to the wall by drilling through the back rail. Mark the hole positions on the wall with a pencil.

Drill the wall at the marked positions with a suitable bit and secure the cabinet to the wall using correct fixings for the wall type.

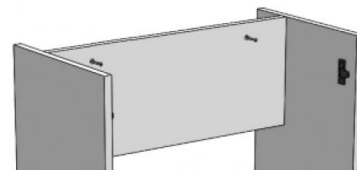

To cut the lower front panel to accommodate the toilet soil pipe and cistern flush pipe, use a jigsaw with a fine-toothed blade suitable for timber. Ensure that the room is well ventilated when cutting the material.

All cut edges must be sealed with paint, PVA glue or good quality sanitary grade silicone sealant to prevent the ingress of moisture.

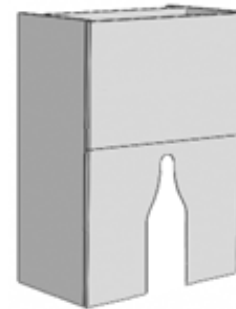

Replace the panels on the toilet unit, fitting the lower fascia first. It is good practise to run a bead of silicone where the furniture meets the floor and walls.

Care & Maintenance

Furniture should be regularly dusted with a soft cotton or micro-fibre cloth. For more thorough cleaning, occasionally wipe your furniture with a soft cloth dampened with a mild detergent solution. Surfaces should be thoroughly dried with a lint free cloth to prevent watermarks. Under no circumstances should solvent cleaning agents, bleach or abrasive cleaning agents or cloths be used. Spills should be removed immediately using a clean cloth. All bathroom furniture will deteriorate through prolonged periods of exposure to high levels of condensation so bathrooms must be adequately ventilated using suitable extraction. Failure to ensure adequate ventilation may invalidate your guarantee.

Important Information

- Read the instructions carefully.
- Check the product for any signs of damage and remove any protective film.
- It is recommended that a technically competent installer undertakes installation.
- It is the installer's responsibility to carry out a thorough assessment of the wall type and the weight of the product and use appropriate fixings.
- Care should be taken when drilling walls to avoid any hidden wires or pipes.
- Ensure that the electrical supply is turned off before commencing any work. It is recommended that this product is fitted by a suitably qualified Part P registered electrician in accordance with current IEE & Building Regulations.

Installation

Push the plastic inserts into the rear of the mirror panel. Ensure that the inserts are aligned in the correct direction with the smaller diameter of the hole at the top. Once the plastic inserts have been fitted, they cannot be removed.

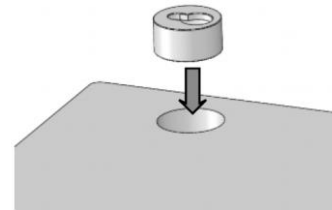

Measure the distance between the centres of the two plastic inserts. Transfer this measurement onto the wall, ensuring that it is level using a spirit level. The electrical feed for the illuminated mirror (supplied separately) should pass through the hole in the centre of the mirror panel when it is hung on the wall.

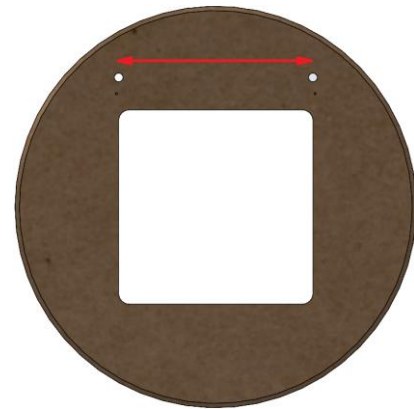

Alternatively, use the square cut-out section in the centre to square the mirror on the wall using a spirit level. The fixing holes can then be transferred to the wall using a pencil.

Drill the wall and secure the fixings at the marked positions. Plasterboard or stud walls may require specialist fixings (not supplied). **Note:** you must ensure that the fixings are suitable for the weight of the mirror and the wall type.

Pass the electrical feed through the centre of the mirror panel and hang it on the wall fixings, ensuring that they are located securely in the plastic inserts.

Screw the 10 x $\frac{3}{4}$ pan head screws into the holes made in the front of the frame. Ensure that the screws protrude enough for the illuminated mirror (supplied separately) to be hung securely.

Connect the electrical feed to the illuminated mirror (supplied separately) and hang it onto the 10x $\frac{3}{4}$ pan head screws, ensuring that it is securely located.

If required, the bottom of the mirror can be secured to the back panel using a suitable adhesive.

Care & Maintenance

Furniture should be regularly dusted with a soft cotton or micro-fibre cloth. For more thorough cleaning, occasionally wipe your furniture with a soft cloth dampened with a mild detergent solution. Surfaces should be thoroughly dried with a lint free cloth to prevent watermarks. Under no circumstances should solvent cleaning agents, bleach or abrasive cleaning agents or cloths be used. Glass or mirrored panels should be cleaned using a non-solvent based glass cleaner and a soft cloth. Spills should be removed immediately using a clean cloth. All bathroom furniture will deteriorate through prolonged periods of exposure to high levels of condensation so bathrooms must be adequately ventilated using suitable extraction. Failure to ensure adequate ventilation may invalidate your guarantee.

Installation Guide

Chic Bath Side Panel

Important Information

- Read the instructions carefully.
- Check the product for any signs of damage and remove any protective film.
- It is recommended that a technically competent installer undertakes installation.
- It is the installer's responsibility to carry out a thorough assessment of the wall type and use appropriate fixings.
- Care should be taken when drilling walls to avoid any hidden wires or pipes.

Installation

Set the height of the bath to suit the height of the bath panel according to the instructions supplied with the bath. If you are installing this side panel in conjunction with an end panel, fit the end panel first according to the instructions supplied with it.

Screw three black Keku clips to the underside of the wooden batten underneath the bath rim using the screws provided. The three clips should be equally spaced along the length of the bath. Use the diagram as a guide to how the Keku clips are fitted.

The matching Keku clips should be screwed to the rear of the bath panel using the screws supplied. Measure carefully to ensure that the clips on the rear of the bath panel will engage with the clips screwed to the bath.

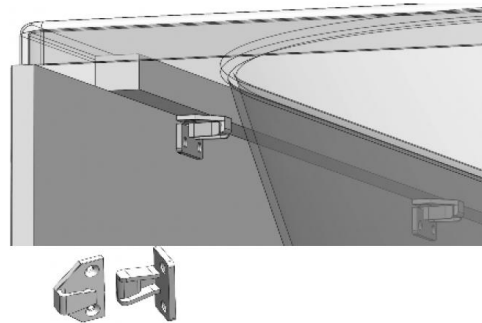

If the bath panel is being fitted between two walls, the two "L" brackets should be secured to the walls to prevent the panel from being pushed inwards. Ensure suitable fixings are used.

Once fully installed, seal around the bath panel on all joints using a good quality, sanitary-grade silicone sealant.

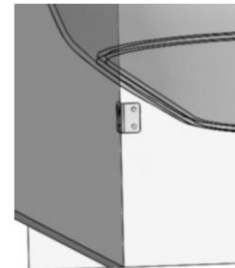

Care & Maintenance

Furniture should be regularly dusted with a soft cotton or micro-fibre cloth. For more thorough cleaning, occasionally wipe your furniture with a soft cloth dampened with a mild detergent solution. Surfaces should be thoroughly dried with a lint free cloth to prevent watermarks. Under no circumstances should solvent cleaning agents, bleach or abrasive cleaning agents or cloths be used. Spills should be removed immediately using a clean cloth. All bathroom furniture will deteriorate through prolonged periods of exposure to high levels of condensation so bathrooms must be adequately ventilated using suitable extraction. Failure to ensure adequate ventilation may invalidate your guarantee.

Installation Guide

Chic Bath End Panel

Important Information

- Read the instructions carefully.
- Check the product for any signs of damage and remove any protective film.
- It is recommended that a technically competent installer undertakes installation.
- It is the installer's responsibility to carry out a thorough assessment of the wall type and use appropriate fixings.
- Care should be taken when drilling to avoid any hidden wires or pipes.

Installation

Set the height of the bath to suit the height of the bath panel according to the instructions supplied with the bath.

Fit the end panel before installing the side panel.

Secure one "L" bracket to the wall using suitable fixings. It is recommended that the bracket is fitted 300mm vertically from the underside of the bath.

Secure the second "L" bracket to the underside of the wooden batten under the bath rim using the screws provided.

Screw one of the black Keku clips to the opposite side of the end panel to the wall. The matching Keku clip should be screwed to the back of the front panel. Use the diagram as a guide to how these are fitted.

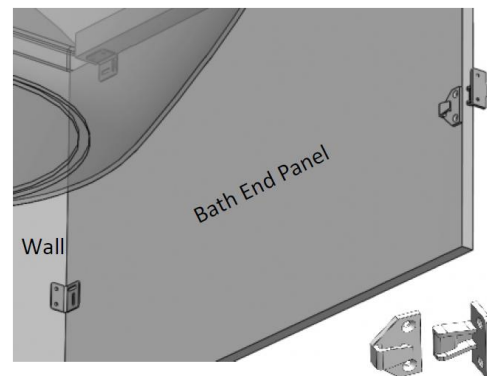

Once fully installed, seal around the bath panel on all joints using a good quality, sanitary-grade silicone sealant.

Care & Maintenance

Furniture should be regularly dusted with a soft cotton or micro-fibre cloth. For more thorough cleaning, occasionally wipe your furniture with a soft cloth dampened with a mild detergent solution. Surfaces should be thoroughly dried with a lint free cloth to prevent watermarks. Under no circumstances should solvent cleaning agents, bleach or abrasive cleaning agents or cloths be used. Spills should be removed immediately using a clean cloth. All bathroom furniture will deteriorate through prolonged periods of exposure to high levels of condensation so bathrooms must be adequately ventilated using suitable extraction. Failure to ensure adequate ventilation may invalidate your guarantee.